

2"R W/ C.I. PLUG
FOR INSPECTION
OPENINGS
(2) PLC'S.

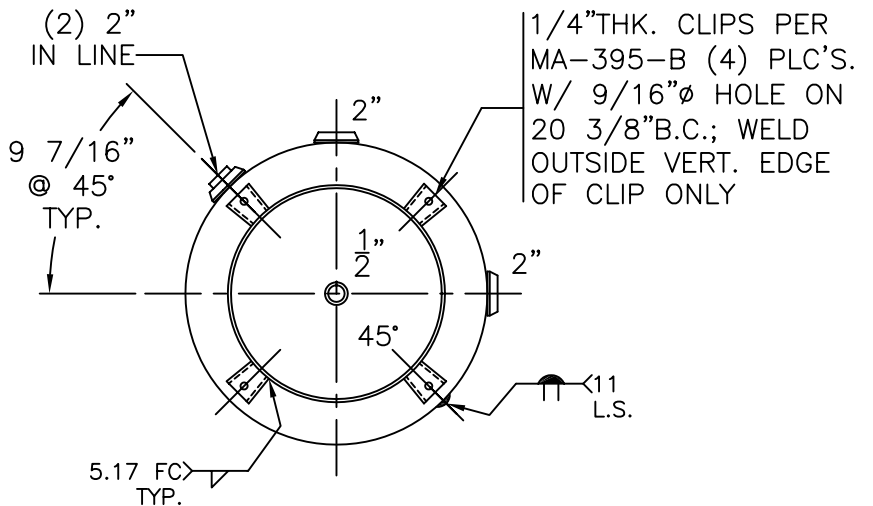
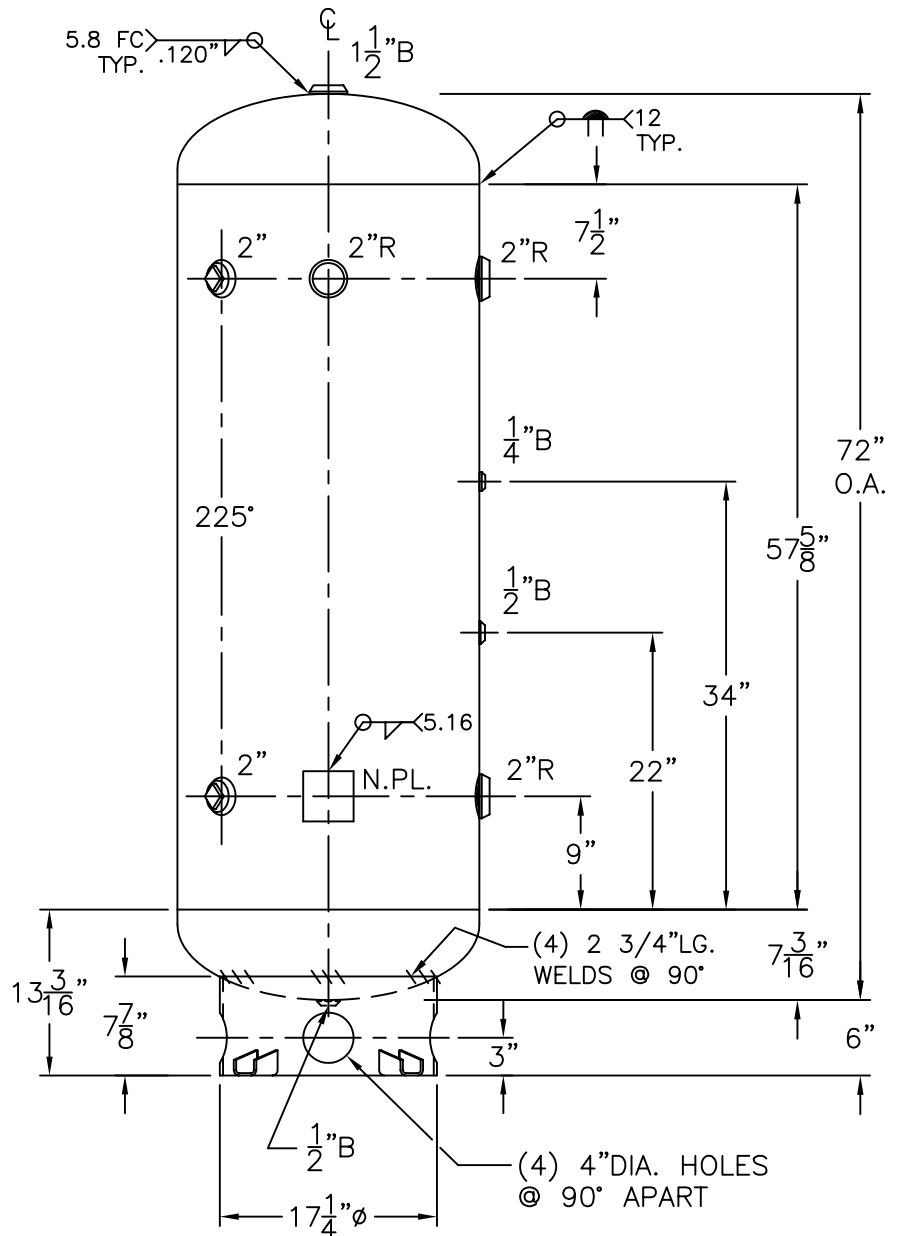

NOTE: 1) HYDRO @ 392 PSIG. MIN.

SHELL / HEADS	
.200" SA-455	2.1: S.E.
JOGGLE - .209" OFFSET	
(.196" MIN.)	
.200" SA-455	
M.A.W.P.	300 PSIG. @ 400 °F
M.D.M.T.	-20 °F @ 300 PSIG.
ASME: SECTION VIII	DIV. 1, 2007 ADD 2007
X-RAY:	RT-4 SPOT L.S. ONLY
GALLONS:	130
SERIAL NO.	WT. 375 LBS.
N.B.	

24-VD-130-R	REV. 9-18-08
FOR: HANSON STANDARD	DATE: 11-22-86
VERT. AIR TANK	
INSIDE: UNPAINTED	
OUTSIDE: PRIME	
BY: E.S.	SCALE: 3/4"=12"
ROY F. HANSON JR. MFG.	
1600 E. WASHINGTON BLVD.	
LOS ANGELES, CA 90021	