

- NOTE: 1) HYDRO @ 262 PSIG. MIN.
 2) IMPACT TESTED? NO UG-20(f).
 3) CRN-ALBERTA, ONTARIO-U4777.25

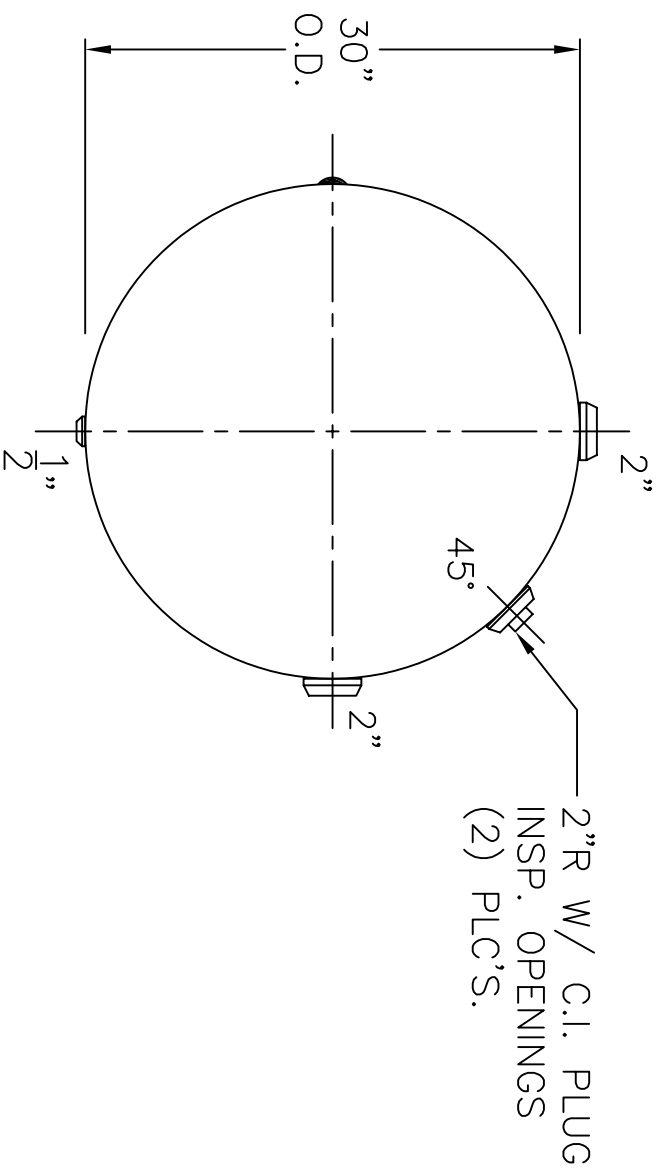

VIEW W/O SUPPORTS

SHELL / HEADS		.166" SA-414-G 2:1 S.E. (.164" MIN.)	
JOGGLE-.149" OFFSET			
.165" SA-414-G			
M.A.W.P.	200 PSIG. @ 400 °F		
M.D.M.T.	-20 °F @ 200 PSIG.		
ASME SECTION VIII DIV. 1, 2007 ADD 2007			
X-RAY:	RT-4 SPOT L.S.		
GALLONS:	240 WT. 499 LBS.		
SERIAL NO.			
N.B.			
INSIDE: UNPAINTED		REV. 11-7-08	
OUTSIDE: PRIME		DATE: 12-1-87	
CAD-"B" SIZE UNDER "STD"-SERIES		FOR: HANSON STANDARD	
BY: E.S. SCALE: 1"=12"		HORIZ. AIR TANK	
ROY E. HANSON JR. MFG.		INSIDE: UNPAINTED	
1600 E. WASHINGTON BLVD.			
LOS ANGELES, CA 90021			