

1 1/4" - 3000#
FULL CPLG.
FOR ANODE

2 1/2" B W/LONG PILOT
(3) PLC'S

1 1/2" - 3000#
FULL CPLG.

3/4" Ø SOLAR
L.LUG

1/4" x 1/4" x 5.2 FC
TYP.

CL

L.L.
N.S.

12 TYP.

3/4" B

158°

RAISED
N.P.L.

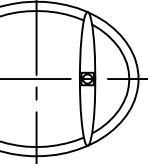

CL

158°

3/4" B

1 1/4" B

14"
9"
4"

13 7/6"

2 1/2"

5/32" x 5/32" x 5.2 FC

(4) 4" x 4" x 1/4" THK. x
22 15/16" LG. ANGLE LEGS

(4) 6" x 6" x 1/2" THK.
PAD W/ 7/8" Ø HOLE
FOR 5/8" Ø x 8" LG. BOLTS
GRADE 5 OR BETTER
6" EMBEDMENT

NOTE: 1) SHIP LOOSE W/(1) 1 5/16" x 96" LG. FLEX. MAG. ANODE.
2) HYDRO @ 240 PSIG.
3) 4-22-04 PROOF TEST.

SHELL / HEADS	
.250" SA-414-G	2:1 S.E.
JOGGLE - .198	OFFSET
.200" SA-455	
M.A.W.P.	160 PSIG. @ 210 °F
ASME SECTION	IV 2010 ADD. 2010
X-RAY:	RT-NO / H.L.W.
GALLONS:	712 WT. 1184 LBS.
SERIAL NO.	
N.B.	

GS-48-712-V	REV. 7-14-11
DATE: 1-24-03	
FOR: HANSON STANDARD	
VERT. WATER TANK.	
SURFACE AREA = 113.0 SQ. FT.	
INSIDE: GLASS LINED	
OUTSIDE: PRIME	
LEG-ZONE 4-15 KM.	
CAD-"B" UNDER "STD"-SERIES	
BY: J.G.	SCALE: 3/4"=12"
ROY E. HANSON JR. MFG.	
1600 E. WASHINGTON BLVD.	
LOS ANGELES, CA 90021	

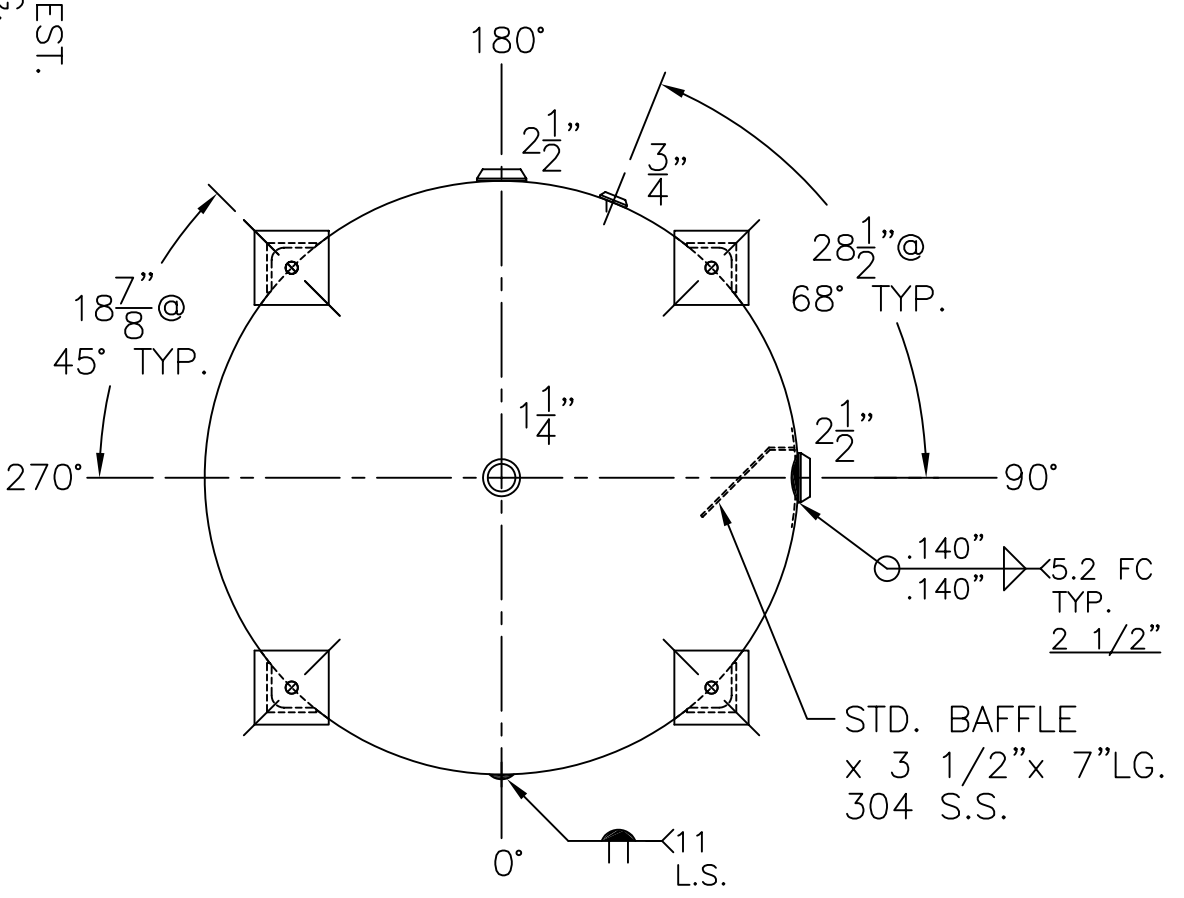

STD. BAFFLE
x 3 1/2" x 7" LG.
304 S.S.

11 L.S.