

DATE	BY
3-1-16	JG
4-19-16	JG

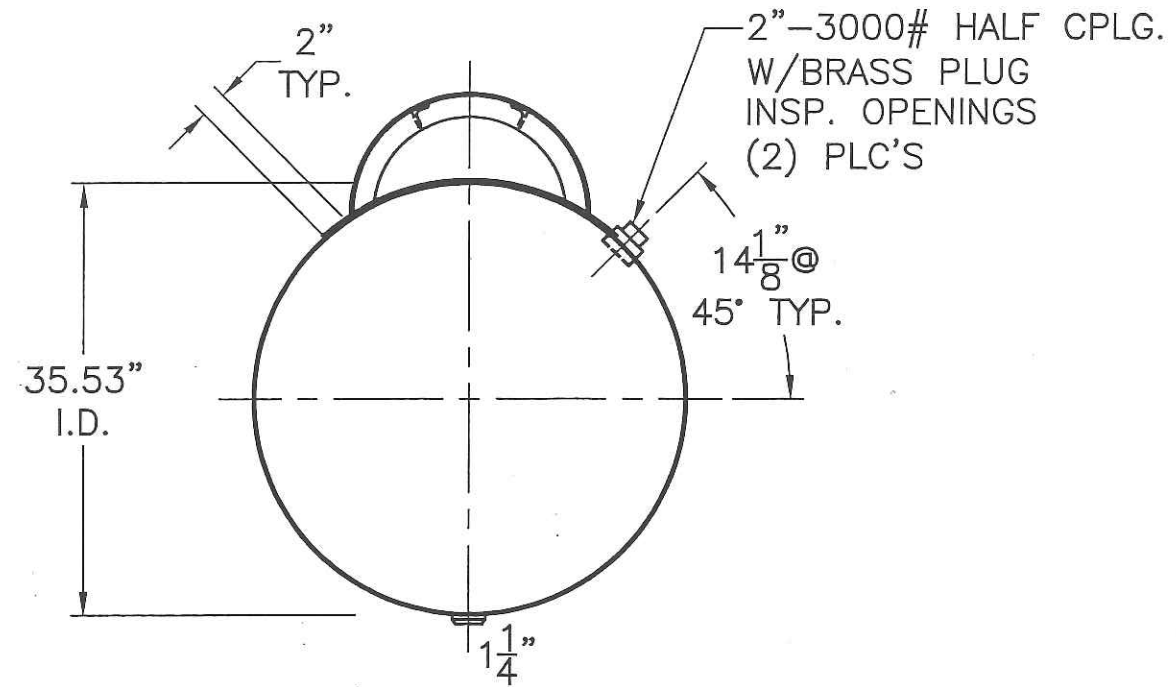
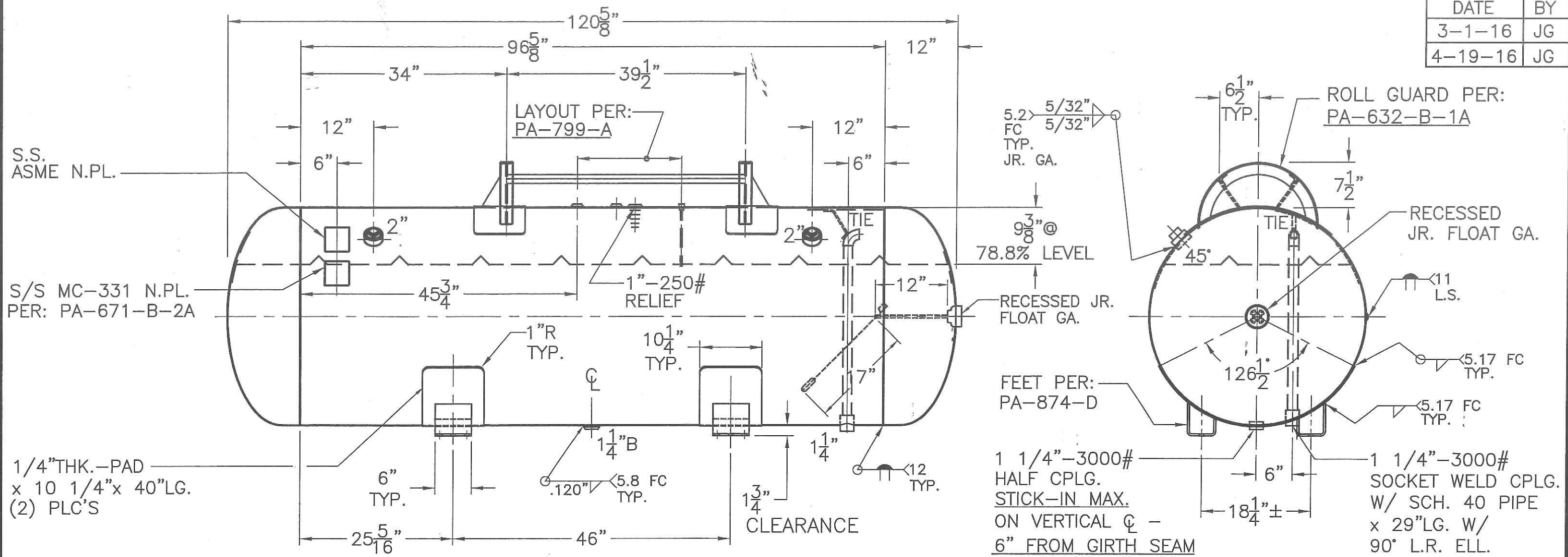

VIEW W/O SUPPORTS

NOTE: 1) HYDRO @ 375 PSIG. MIN.

HEADS	.238" SA-455 2:1 S.E.	PA-671-B	REV. 4-19-16
	JOGGLE		DATE: 7-27-95
SHELL	.282" SA-455	FOR:	
		HORIZ. DOT, MC-331 LPG TANK	
M.A.W.P. 250 PSIG. @ 200 °F		SURFACE AREA = 100.1 SQ. FT.	
M.D.M.T. -20 °F @ 250 PSIG.		C.F.M. REQ'D. = 2344	
ASME. SECTION VIII DIV. 1, 2015		INSIDE: UNPAINTED, DEHYDRATED	
X-RAY: RT-4 SPOT L.S. & G.S.		OUTSIDE: PRIME	
GALLONS: 499 WT. 1265 LBS.		BY: E.S. / B.C. SCALE: 3/4" = 12"	
SERIAL NO.		ROY E. HANSON JR. MFG.	
N.B.		LOS ANGELES, CA 90021	