

(3) 2 1/2" x 2 1/2" x 3/16" THK. x 20 1/8" LG. ANGLE LEGS

(3) 4" x 4" x 5/16" THK. PAD W/7/8" Ø HOLE FOR 5/8" Ø x 8" LG BOLTS GRADE 5 OR BETTER 6 EMBEDMENT

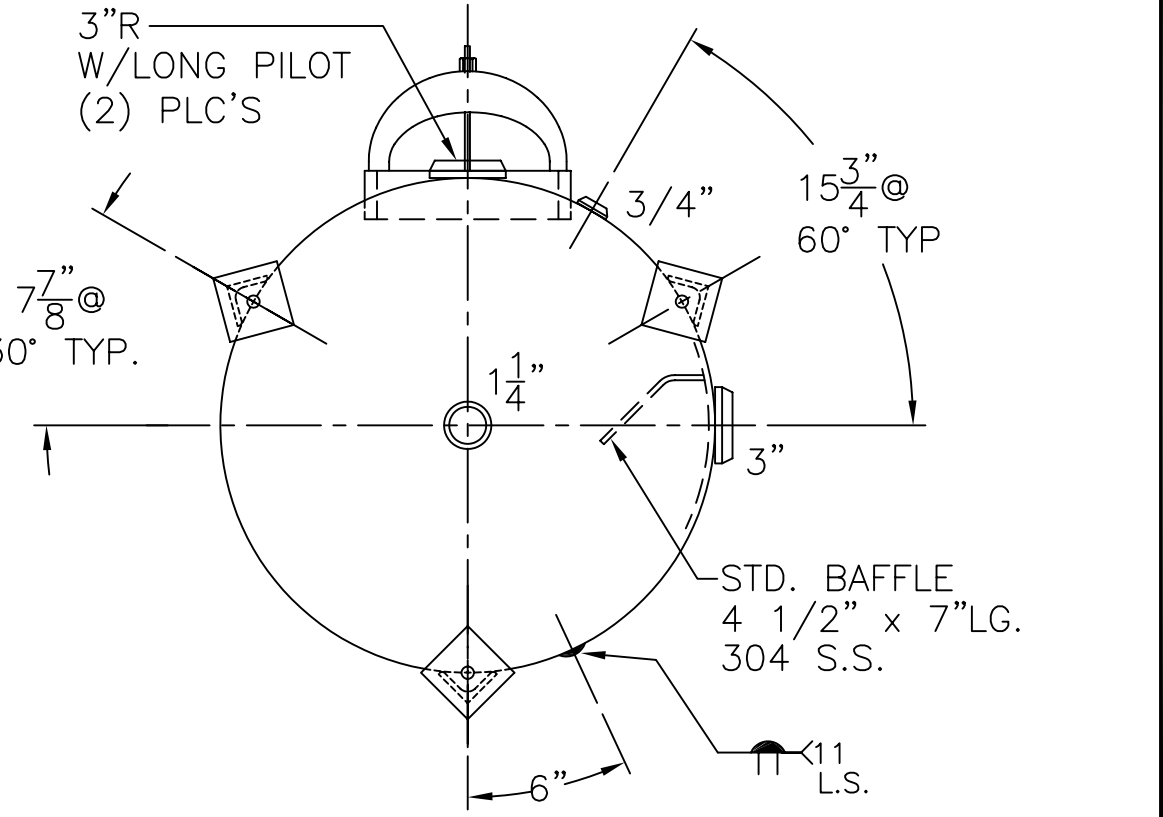

NOTE: 1) SHIP LOOSE W/(1) 1 5/16" x 48" LG. FLEX MAG. ANODE.
 2) 4-1-04 PROOF TEST.
 3) 240 PSIG. HYDRO.
 4) CRN #1623.7891

SHELL / HEADS		M.A.W.P. 160 PSIG. @ 210 °F	
.166" SA-414-G 2:1 S.E.		ASME SECTION IV 2007 ADD 2008	
JOGGLE - .149 OFFSET		X-RAY: RT-NO / H.L.W.	
.165" SA-414-G		GALLONS: 235 WT. 523 LBS.	
SERIAL NO.		N.B.	
FOR: HANSON STANDARD		LEG-ZONE 4-15 KM.	
VERT. WATER TANK		BY: J.G.	
SURFACE AREA = 58.0 SQ. FT.		SCALE: 1" = 12"	
INSIDE: GLASS LINED		ROY E. HANSON JR. MFG.	
OUTSIDE: PRIME		1600 E. WASHINGTON BLVD.	
WL-106-B		LOS ANGELES, CA 90021	
REV. 3-18-09			
DATE: 5-23-05			