

END VIEW W/OUT SUPPORTS

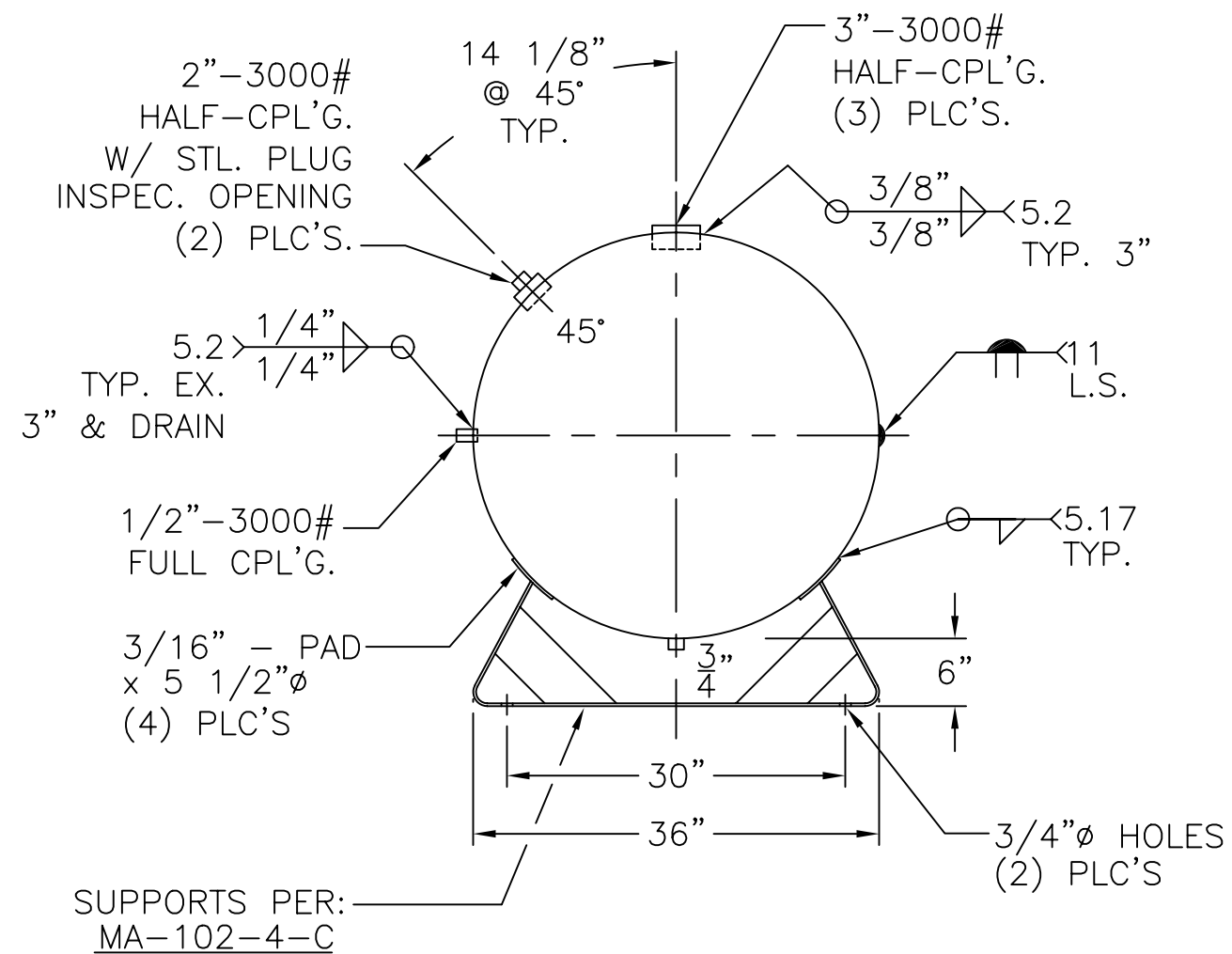

NOTE: 1) HYDRO @ 715 PSIG. MIN.
 2) PRE-HEAT ALL WELDS TO 150°F.

SHELL / HEADS	.500" SA-516-70 2:1 S.E. (.483"MIN.) TRIM	36-HK-400-W	REV. 11-19-02
			DATE: 5-14-87
		FOR: HANSON STANDARD HORIZ. AIR TANK	
	.500" SA-455		
		INSIDE: UNPAINTED	
	M.A.W.P. 550 PSIG. @ 400 °F		
	M.D.M.T. -20 °F @ 550 PSIG.		
	ASME SECTION VIII DIV. 1, 2001		
	X-RAY: RT-2, 100%L.S. & SPOT HD. G.S.		
	GALLONS: 400	WT. 1767 LBS.	
	SERIAL NO.		
		ROY E. HANSON JR. MFG. 1924 COMPTON AVE. LOS ANGELES, CA 90011	